



## External Blinds - Grinotex<sup>®</sup>, Grinotex Sinus<sup>®</sup>



The composite metal gathering Blind Grinotex<sup>®</sup> is a weather-resistant and extremely durable louver blind system. This is ensured by the indestructible lifting and drive chains made of steel, the louver connections made of stainless steel cable with UV-resistant plastic sheathing and the robust guides and the solid lower rail. In addition to this the louvers can be snugly closed with plastic sealing lips and ensure good darkening. Thanks to the anti-lifting feature which works in any position Grinotex<sup>®</sup> is not least used where unauthorised entry protection is required. Self-supporting, sturdy, cleaning and service-friendly blind design.



min. 600mm, crank drive  
min. 760mm, motor drive  
max. 800mm, gearbox in slat area  
max. 4000mm



min. 380mm  
max. 4250mm



max. 8m<sup>2</sup>, single blind  
max. 24m<sup>2</sup>, connected systems with motor drive



## TECHNICAL SPECIFICATIONS & FEATURES

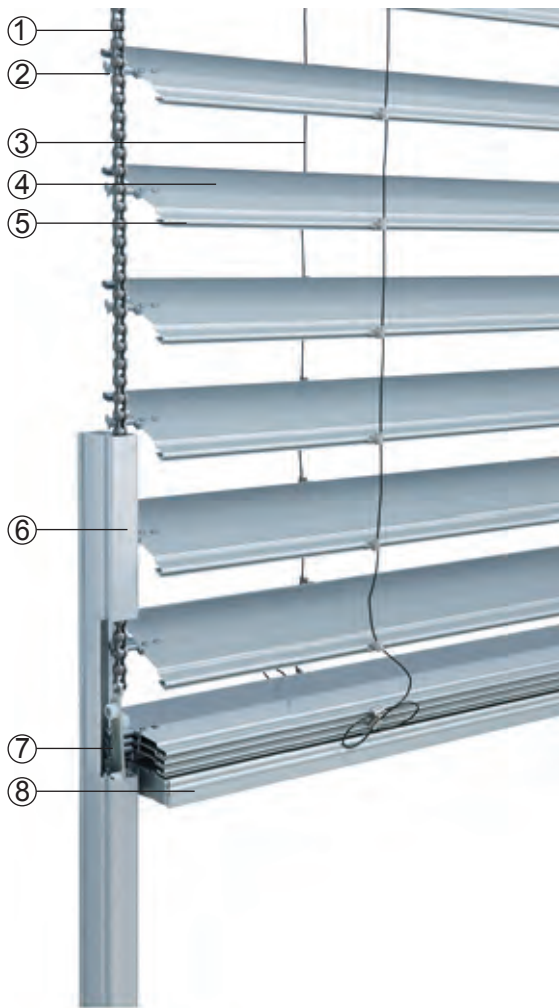

### External venetian blind with metal joints for durability.

1. Lifting chain and drive chain made from steel.
2. Guide pin at all slat ends.
3. Slat support connection: stainless steel wire cable coated with UV-stable plastic.
4. Slim and smooth-surfaced slat profile, easy to clean.
5. Plastic sealing lip.
6. Guide rail with integrated lifting mechanism.
7. Stable end rail guide.
8. Robust end rail made from extruded aluminum.



Safety locking device in each position.

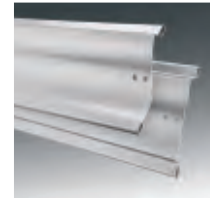

Two different slat designs: Grinotex® or Grinotex Sinus®.



Safety sensing edge.



Grinotex Sinus®: more use of daylight, less glare with a slat position of approx. 45°.

## Limit dimensions

*bk* - width of construction  
(rear edge of guide rails)

Minimum  
 - Crank drive 600mm  
 - Gearbox in slat area 800mm  
 - Motor drive 760mm  
 Maximum 4000mm  
 Buildings and high-rise structures which are exposed to high wind should decrease this maximum value as required.

*hl* - opening height

Minimum 380mm  
 Maximum 4250mm

*bk* x *hl* maximum surface area

Single blind  
 - With crank drive 8m<sup>2</sup>  
 - With motor drive 8m<sup>2</sup>

Connected systems

(Max. system width 10m)

- With crank drive  
 2 blinds 8m<sup>2</sup>  
 3 blinds (max.) 6,5m<sup>2</sup>

In the case of 3 connected blinds, the drive should be positioned between two blinds.

- With motor drive  
 2 blinds 16m<sup>2</sup>  
 3-4 blind(max.) 24m<sup>2</sup>

For 3 or 4 blinds, the motor should be positioned in the centre.

Side elevation: Example of header

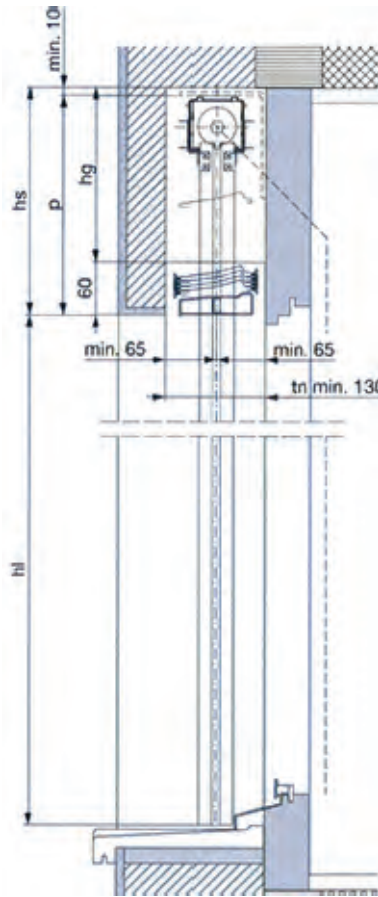

Side elevation: Example with cover

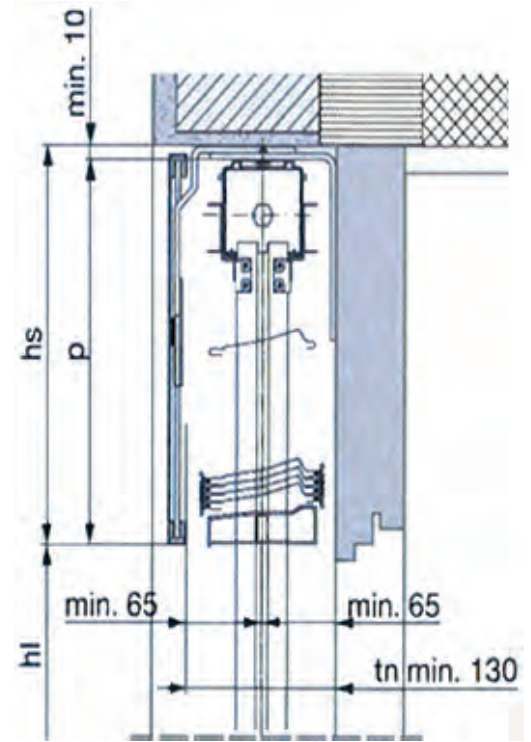

Guide rails

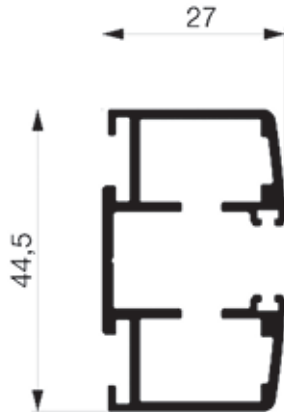

### Key

**bk** = width of construction  
**hl** = opening height  
**p** = height of package  
**hs** = header height (p + min.10)  
**hg** = height of gearbox recess (hs - 60)  
**tn** = depth of niche

All dimensions in mm.

Top elevation for crank drive

With recess (white) for gearbox (not necessary for motor drive).

x = Dimension from rear edge of guide rails to center of drive; depending on window construction - min. 25mm.

With gearbox in slat area: hs + 20mm.

A dimensional tolerance of ±5mm is observed for the header height. Depth of niche tn: 130mm + possible addition for protruding weather board or doorknobs. In crank drive is in slat area: maximum surface area and crank position available on request.

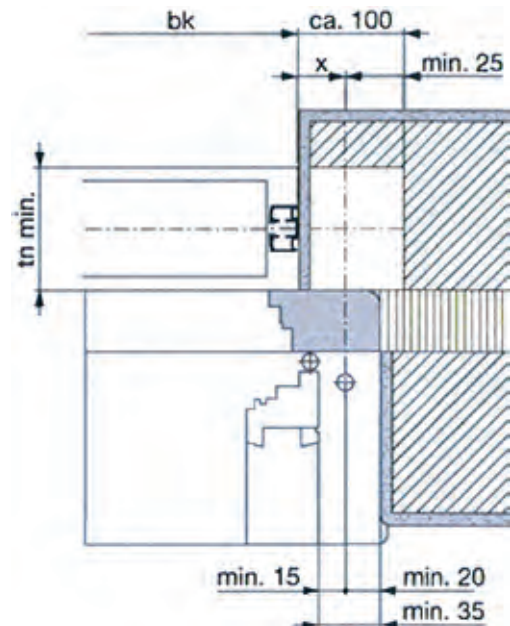

**Grinotex® header dimensions (hs)**

hl	bk up to 2000	2001 -2250	2251 -2500	2501 -2750	2751 -3000	3001 -3250	3251 -3500	3501 -3750	3751 -4000
up to 1250	230	230	230	245	245	245	255	255	255
1251-1500	245	245	245	260	260	260	275	275	275
1501-1750	265	265	280	280	280	290	290	290	290
1751-2000	280	280	295	295	295	310	310	310	310
2001-2250	300	300	315	315	315	325	325	325	325
2251-2500	315	315	330	330	345	345	345	345	
2501-2750	335	335	350	350	360	360			
2751-3000	350	365	365	365	380				
3001-3250	370	385	385	385					
3251-3500	390	405	405						
3501-3750	410	425	425						
3751-4000	425	440							
4001-4250	445	460							
End rail	23mm	38mm	50mm						



Header dimensions are approximate values that may exhibit negative or positive deviations depending on the technical circumstances.

**Grinotex Sinus® header dimensions (hs)**

hl	bk up to 2000	2001 -2250	2251 -2500	2501 -2750	2751 -3000	3001 -3250	3251 -3500	3501 -3750	3751 -4000
up to 750	230	230	230	230	230	230	235	235	235
751-1000	230	230	230	240	240	240	255	255	255
1001-1250	245	245	245	260	260	260	270	270	270
1251-1500	360	260	260	275	275	275	290	290	290
1501-1750	285	285	300	300	300	310	310	310	310
1751-2000	300	300	315	315	315	330	330	330	330
2001-2250	320	320	335	335	335	345	345	345	345
2251-2500	340	340	355	355	365	365	365	365	
2501-2750	355	355	370	370	380	380			
2751-3000	380	395	395	395	405				
3001-3250	395	410	410	410					
3251-3500	410	425	425						
3501-3750	430	445	445						
3751-4000	455	470							
4001-4250	470	485							
End rail	23mm	38mm	50mm						



Header dimensions are approximate values which may exhibit negative or positive deviations depending on the technical circumstances.

## Option

### *Open slat lowering position (Operating position)*

The shade produced when lowering the blinds is often annoying - particularly in the work place. The slat lowering position of around 48 degrees prevents the room from getting dark when the blind is lowered.

## Design description

### *Blind system*

Composite metal technology and guide pins on each individual slat give Grinotex stability in high wind areas. Metal pivotal slat connections and steel cables coated with UV stable plastic lend added system durability. The lateral lifting mechanism operates using steel roller chains with an automatic safety locking feature in every position. A standard reversing edge prevents the blind from being damaged when it encounters obstacles in motion (up to 2250mm in height). Although starting from a closed position, the slats can be adjusted between open and closed at every height.

### *Slats, Grinotex®*

Robust and rigid, the Grinotex® slat resists bending and twisting using rolled edge reinforcement and a plastic sealing lip that offers not only quieter operation, but provides an extra level of light control. Each 93mm slat comes standard with a polyamide guide pin for smooth operation and greater system stability. End rail made from extruded aluminum, transparently anodizes (baked enamel finish for an additional charge).

### *Slat, Grinotex Sinus®*

As well as featuring the tried and tested characteristics of the Grinotex®, Grinotex Sinus® also optimizes use of daylight and glare protection. The robust and particularly rigid slat profile is also extremely elegant and adds that ideas touch to the facade of the building.

### *Guide rail*

Made from extruded aluminum 45x27mm, with weatherproof noise insulation inserts, transparently anodized (baked enamel finish for an additional charge).

### *Housing*

Made from galvanized sheet steel, open at the bottom, with wind-stable slat adjustment mechanism.

### *Fixed fitting*

The self-supporting blind design preserves the insulation in the header and reduces service costs. Up to a width of 2000mm the system requires no fastening for the housing - the insulation remains intact and noise transfer is reduced. The stable guide rails (45x27) feature service openings. Integrated guide rails are available on request.





## Colors

---

### *GriColors*

The GriColors range include 100 color shades in four collections, Glass & Stone, Sun & Fire, Water & Moss and Earth & Wood - from cool white and sunny red to natural blue and earthy brown.

---

### *BiColor (option)*

External venetian blinds get a new color; when the outside of the slat is brightly colored, a neutral light tone on the inside can optimize the blind functions (for an additional charge). The interior view shows the colors outside on the border edges. The guides and rails are transparently anodized (baked enamel finish in one color for an additional charge).



## Operating instructions

- The solar shading systems should be retracted if it is windy.
- The systems must not be operated if there is a risk of ice.
- The systems must be accessible for maintenance work.
- Observe the VSR data sheets.

For more information about our services and products and for planning tips, go to [www.griessergroup.com](http://www.griessergroup.com)